

RISER WAYS

AERIAL MARKER BALLS

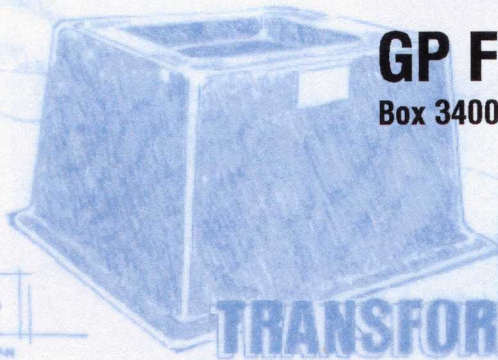

STACK

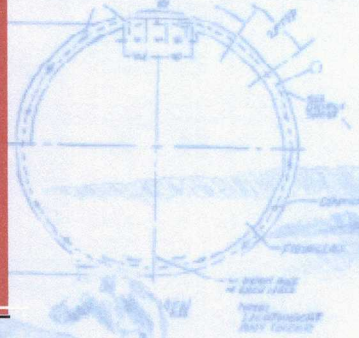
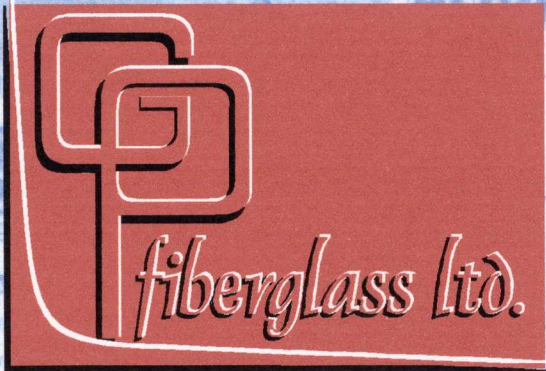

# GP FIBERGLASS LTD.

Box 3400, Melfort, Saskatchewan S0E 1A0

Tel (306) 752-3813

Fax (306) 752-5422

JAN 2002

## TRANSFORMER BOX PADS



EASY TO INSTALL

NEVER NEEDS PAINTING

ANY COLOUR

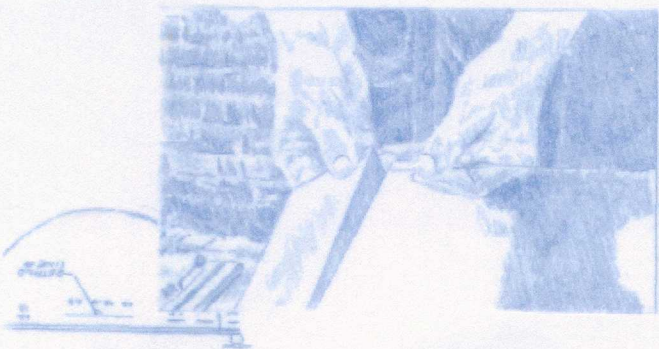
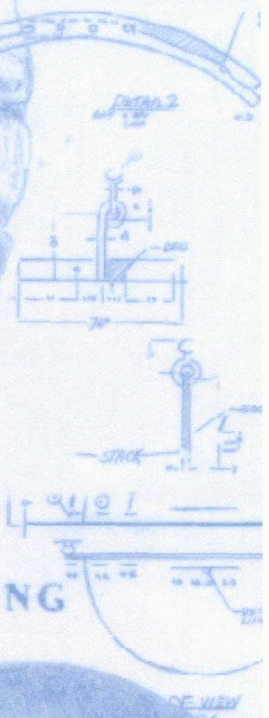
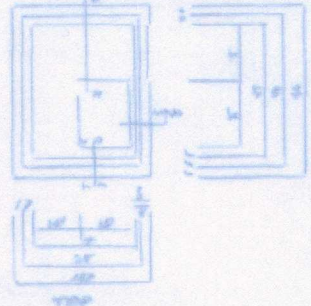
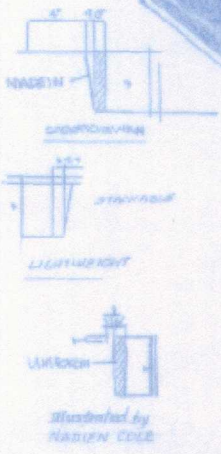

# GP FIBERGLASS LTD.

Box 3400, Melfort, Saskatchewan S0E 1A0

(306) 752-3813

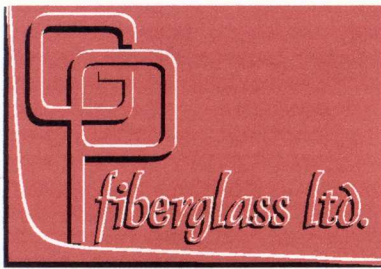

# TRANSFORMER BOX PADS

## FEATURES:

- ◆ Stackable
- ◆ Lightweight
- ◆ Easy to install
- ◆ Never needs painting
- ◆ Adaptable
- ◆ Well designed
- ◆ Economical
- ◆ Special lip on bottom

## BENEFITS:

- ◆ Freight Savings
- ◆ Variety of sizes
- ◆ Variety of shapes
- ◆ Custom knock outs
- ◆ Lids available
- ◆ Minimize storage space

## OPTIONS:

- ◆ Knock outs
- ◆ Lids

## SHIPPING:

- ◆ part is 400 lbs.
- ◆ part is 67 cubic feet
- ◆ 5 per pallet: 171 cubic feet
- ◆ 5 per pallet: 2,200 lbs.
- ◆ 5 per pallet: 72" x 62 1/2" x 75" high

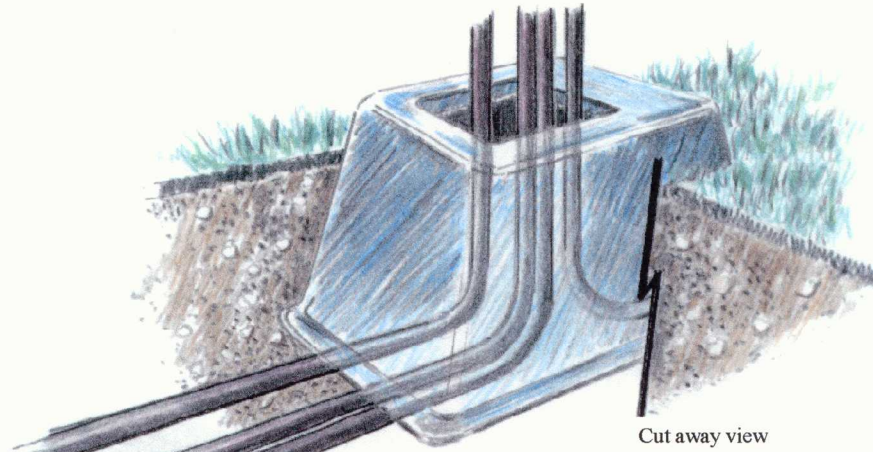

Cables run underneath lip on pad to prevent cutting and damage to cable during frost heave or ground settling

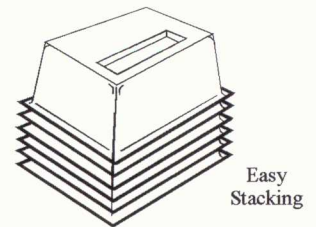

Easy Stacking

## 3 Phase Fiberglass Box Pad for 75 K.V.A. to 300 K.V.A. Transformers

Code (part #): 5-06-00

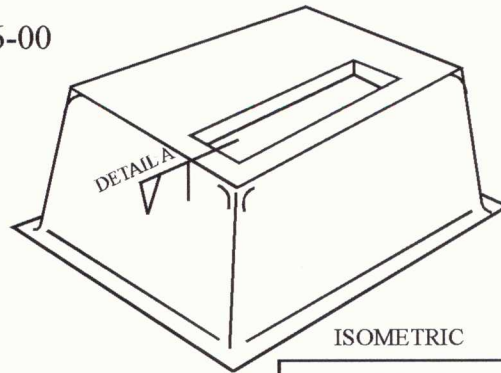

ISOMETRIC

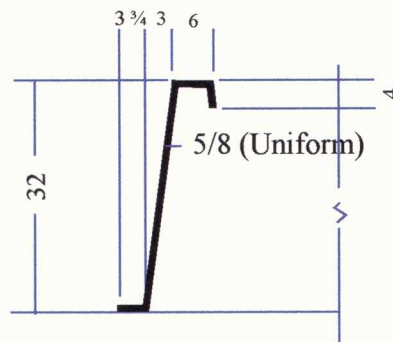

DETAIL A

Note: All dimensions are in inches

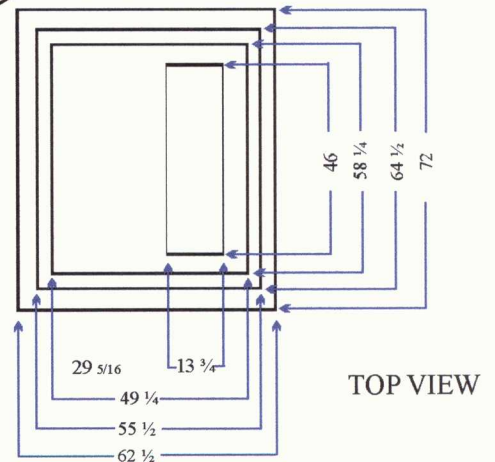

TOP VIEW

G.P. Fiberglass Ltd.  
 Box 3400, Melfort, Saskatchewan  
 CANADA S0E 1A0  
 Phone: (306) 752-3813  
 Fax: (306) 752-5422

All measurements and weights are approximate  
 JANUARY 2002

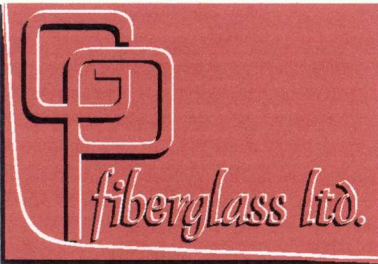

# TRANSFORMER BOX PADS

## FEATURES:

- ◆ Stackable
- ◆ Lightweight
- ◆ Easy to install
- ◆ Never needs painting
- ◆ Adaptable
- ◆ Well designed
- ◆ Economical
- ◆ Special lip on bottom

## BENEFITS:

- ◆ Freight Savings
- ◆ Variety of sizes
- ◆ Variety of shapes
- ◆ Custom knock outs
- ◆ Lids available
- ◆ Minimize storage space

## OPTIONS:

- ◆ Knock outs
- ◆ Lids

## SHIPPING:

- ◆ part is 88 lbs.
- ◆ part is 18 1/2 cubic feet
- ◆ 10 per pallet: 67 cubic feet
- ◆ 10 per pallet: 950 lbs.
- ◆ 10 per pallet: 42" x 54" x 57" high

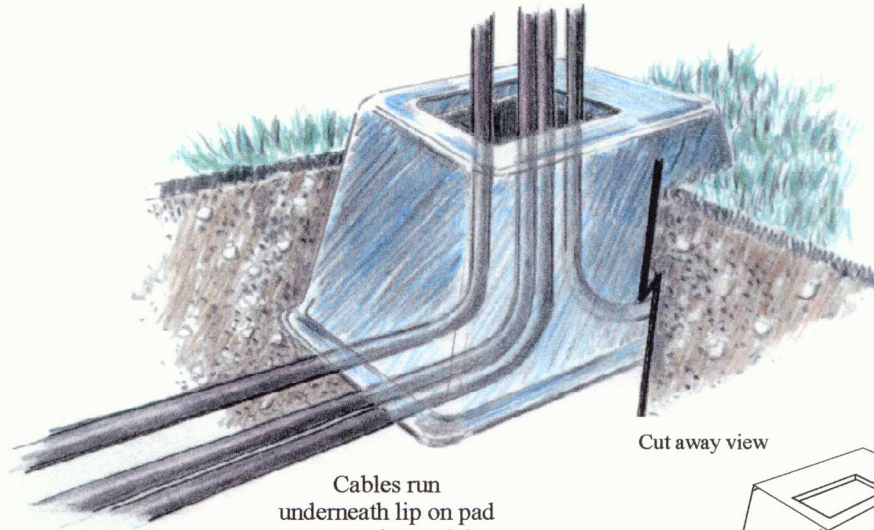

Cut away view

Cables run underneath lip on pad to prevent cutting and damage to cable during frost heave or ground settling

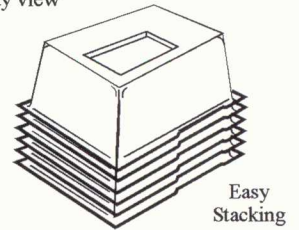

Easy Stacking

## 18 Inch High Fiberglass Box Pad for 15 K.V.A. to 25 K.V.A. Transformers

Code (part #): 5-06-02

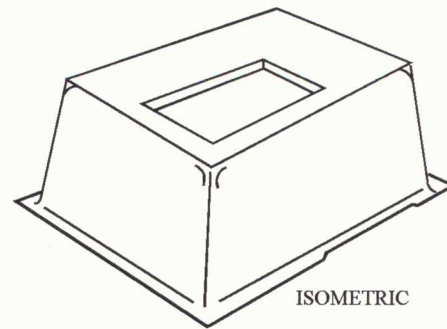
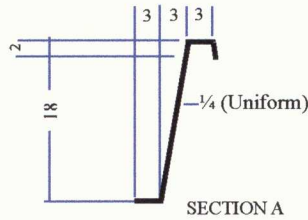

ISOMETRIC

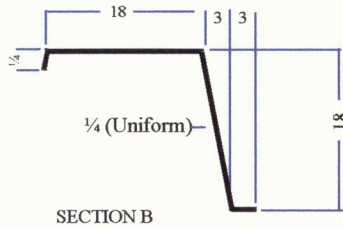

SECTION B

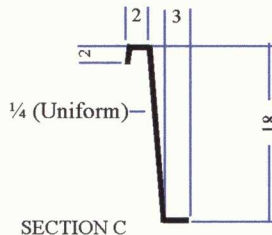

SECTION C

Note: All dimensions are in inches

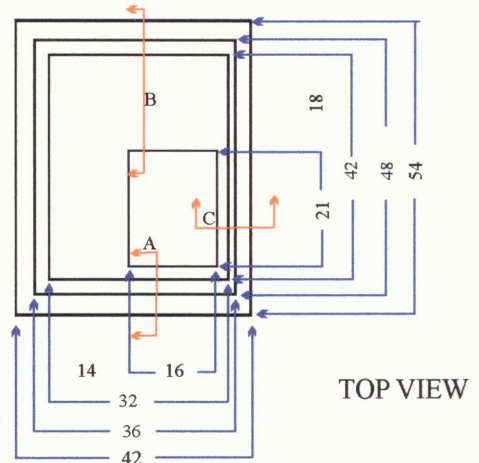

TOP VIEW

All measurements and weights are approximate  
JANUARY 2002

G.P. Fiberglass Ltd.  
Box 3400, Melfort, Saskatchewan  
CANADA S0E 1A0  
Phone: (306) 752-3813  
Fax: (306) 752-5422

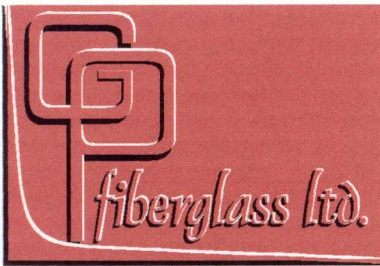

# TRANSFORMER BOX PADS

## FEATURES:

- ◆ Stackable
- ◆ Lightweight
- ◆ Easy to install
- ◆ Never needs painting
- ◆ Extensions available
- ◆ Adaptable
- ◆ Well designed
- ◆ Economical
- ◆ Special lip on bottom

## BENEFITS:

- ◆ Freight Savings
- ◆ Variety of sizes
- ◆ Variety of shapes
- ◆ Custom knock outs
- ◆ Lids available
- ◆ Minimize storage space
- ◆ Adaptor top to change opening size

## OPTIONS:

- ◆ Knock outs
- ◆ Lids
- ◆ Extensions
- ◆ Adaptor plates

## SHIPPING:

- ◆ part is 140 lbs.
- ◆ part is 44 cubic feet
- ◆ 5 per pallet: 81 cubic feet
- ◆ 10 per pallet: 143 cubic feet
- ◆ 5 per pallet: 745 lbs.
- ◆ 5 per pallet: 56"sq. x 5' high
- ◆ 10 per pallet: 1445 lbs.
- ◆ 10 per pallet: 56" x 7'6" high

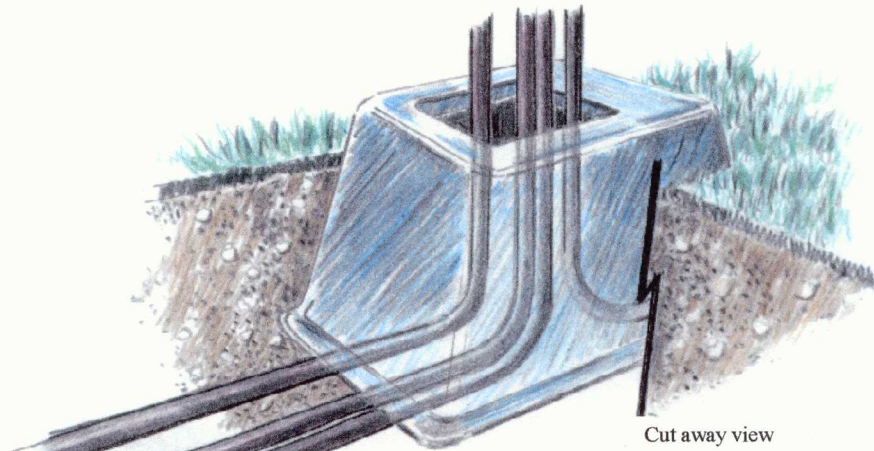

Cut away view

Cables run underneath lip on pad to prevent cutting and damage to cable during frost heave or ground settling

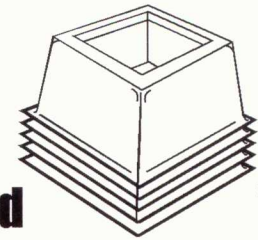

Easy Stacking

## 32 Inch High Fiberglass Box Pad for 25 K.V.A. to 167 K.V.A. Transformers

Code (part #): 5-06-04

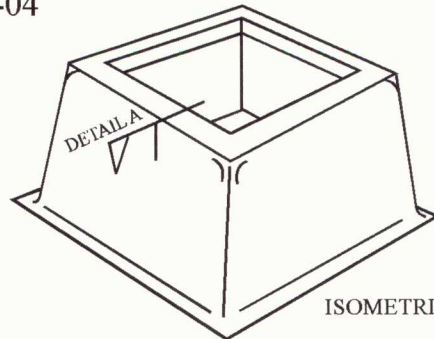

ISOMETRIC

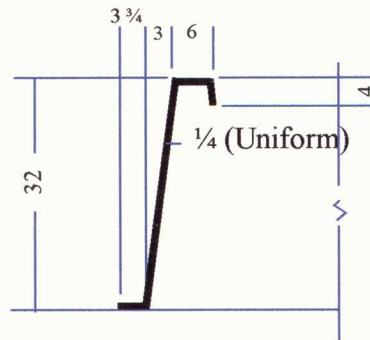

DETAIL A

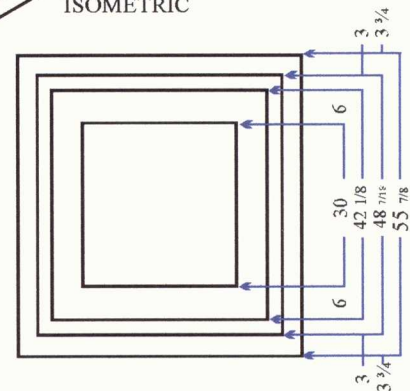

TOP VIEW

Note: All dimensions are in inches

G.P. Fiberglass Ltd.  
 Box 3400, Melfort, Saskatchewan  
 CANADA S0E 1A0  
 Phone: (306) 752-3813  
 Fax: (306) 752-5422

All measurements and weights are approximate  
 JANUARY 2002

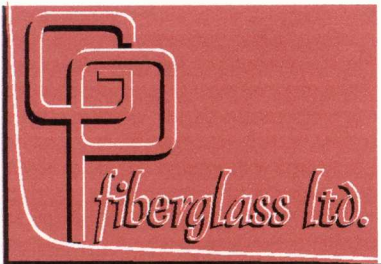

# EXTENSION PAD 9" HIGH

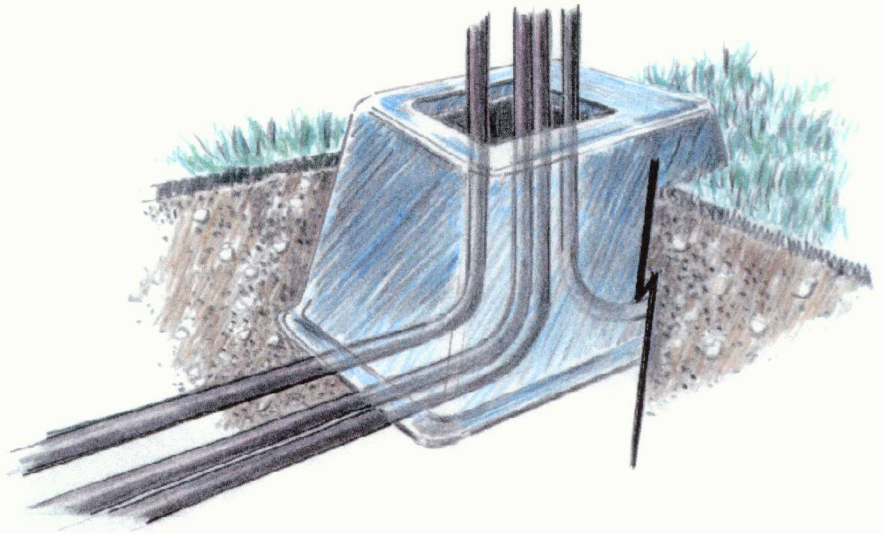

## FEATURES:

- ◆ Stackable
- ◆ Lightweight
- ◆ Easy to install
- ◆ Never needs painting
- ◆ Adaptable
- ◆ Well designed
- ◆ Economical

## BENEFITS:

- ◆ Freight Savings
- ◆ Variety of sizes
- ◆ Variety of shapes
- ◆ Minimize storage space

## SHIPPING:

- ◆ part is 80 lbs.
- ◆ part is 9 cubic feet
- ◆ 5 per pallet :45 cubic feet
- ◆ 5 per pallet : 448lbs.
- ◆ 5 per pallet : 42" sq. x 3.75' High
- ◆ 10 per pallet :90 cubic feet
- ◆ 10 per pallet : 948lbs.
- ◆ 10 per pallet : 42" sq. x 7.5' High

## FIBERGLASS EXTENSION FOR BOX PAD 5-06-04

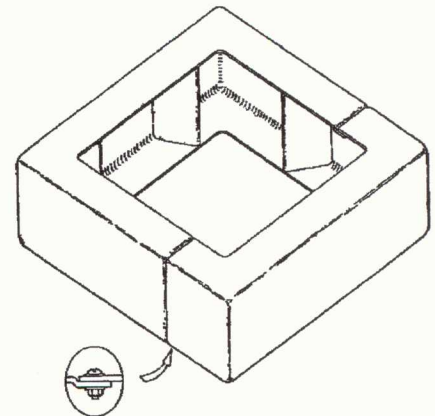

LIP JOINT  
DETAIL

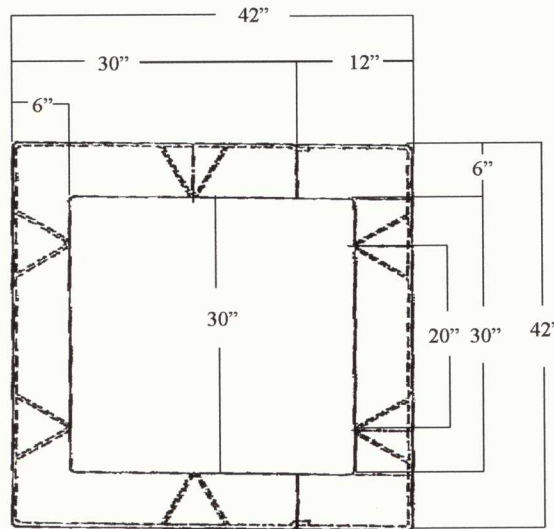

TOP VIEW



FRONT VIEW

NOTE: ALL DIMENSIONS ARE IN INCHES

G.P. Fiberglass Ltd.  
 Box 3400, Melfort, Saskatchewan  
 CANADA S0E 1A0  
 Phone: (306) 752-3813  
 Fax: (306) 752-5422

All measurements and weights are approximate  
 JANUARY 2002



# EXTENSION PAD 6" HIGH

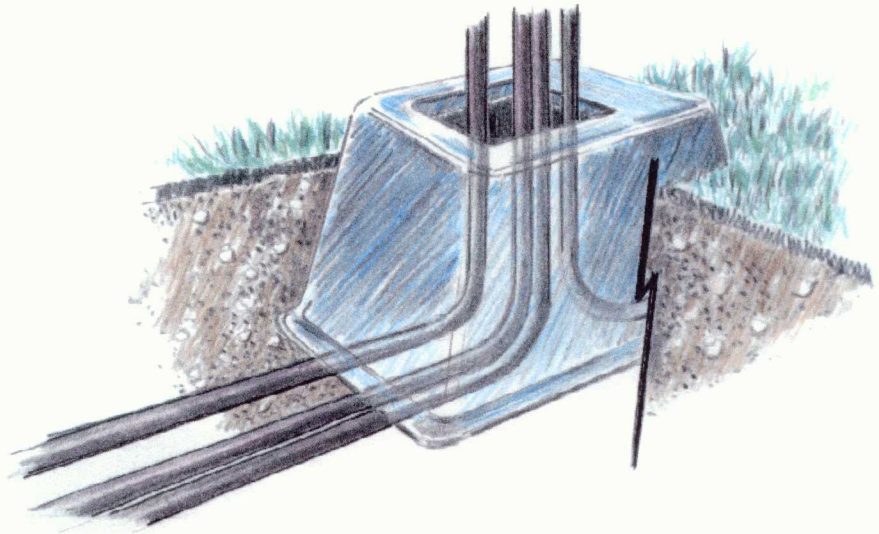

## FEATURES:

- ◆ Stackable
- ◆ Lightweight
- ◆ Easy to install
- ◆ Never needs painting
- ◆ Adaptable
- ◆ Well designed
- ◆ Economical

## BENEFITS:

- ◆ Freight Savings
- ◆ Variety of sizes
- ◆ Variety of shapes
- ◆ Minimize storage space

## SHIPPING:

- ◆ part is 70 lbs.
- ◆ part is 6.125 cubic feet
- ◆ 5 per pallet : 30.625 cubic feet
- ◆ 5 per pallet : 398lbs.
- ◆ 5 per pallet : 42" sq. x 2.5' High
- ◆ 10 per pallet : 61.25 cubic feet
- ◆ 10 per pallet : 748lbs.
- ◆ 10 per pallet : 42" sq. x 5' High

## FIBERGLASS EXTENSION FOR BOX PAD 5-06-04

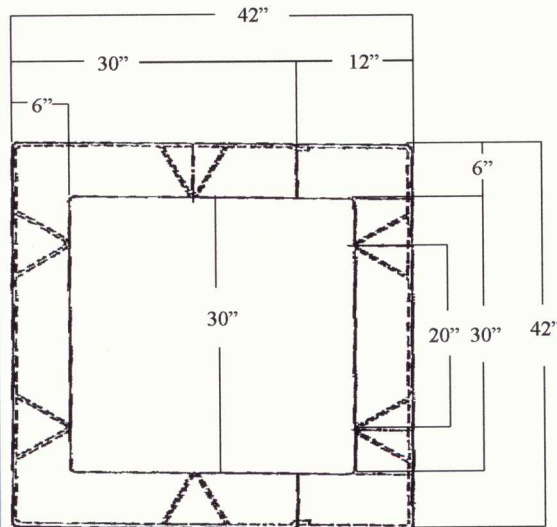

TOP VIEW

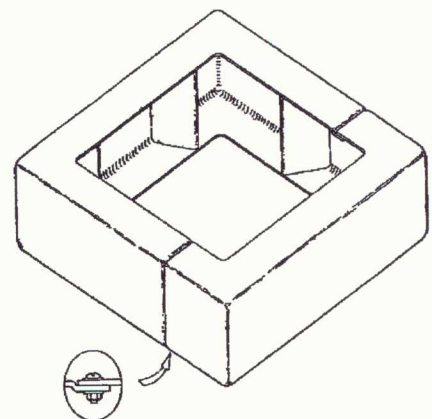

LIP JOINT  
DETAIL



FRONT VIEW

NOTE: ALL DIMENSIONS ARE IN INCHES

G.P. Fiberglass Ltd.  
 Box 3400, Melfort, Saskatchewan  
 CANADA S0E 1A0  
 Phone: (306) 752-3813  
 Fax: (306) 752-5422

All measurements and weights are approximate  
 JANUARY 2002

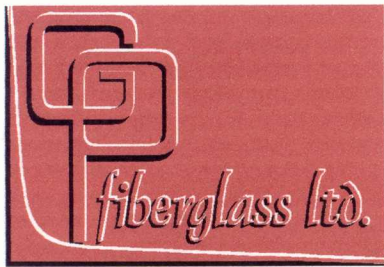

# TRANSFORMER BOX PADS

## FEATURES:

- ◆ Stackable
- ◆ Lightweight
- ◆ Easy to install
- ◆ Never needs painting
- ◆ Extensions available
- ◆ Adaptable
- ◆ Well designed
- ◆ Economical

## BENEFITS:

- ◆ Freight Savings
- ◆ Variety of sizes
- ◆ Variety of shapes
- ◆ Minimize storage space

## OPTIONS:

- ◆ Extensions

## SHIPPING:

- ◆ part is 45 lbs.
- ◆ 30 per pallet: 1400 lbs.
- ◆ 30 per pallet: 43" x 43" x 63" high

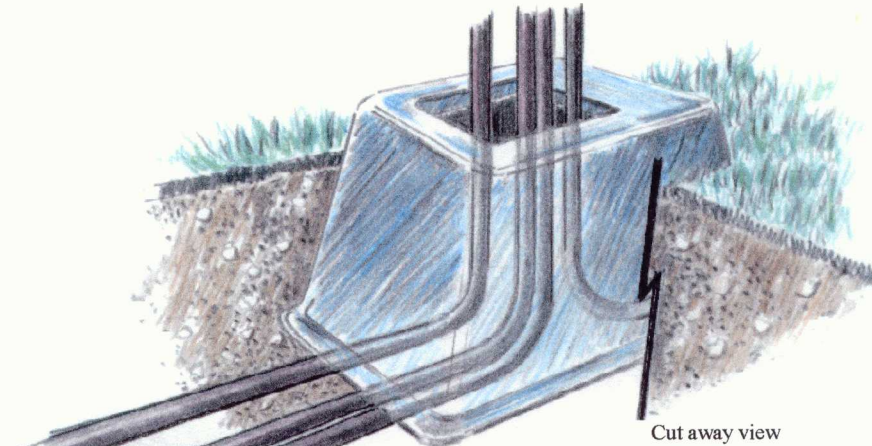

Cut away view

Cables run underneath lip on pad to prevent cutting and damage to cable during frost heave or ground settling

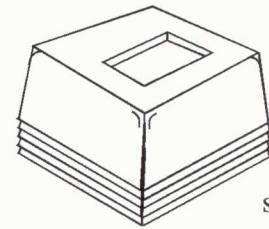

Easy Stacking

## Fiberglass Adapter Top used with item #: 5-06-04

Code (part #): 5-05-96

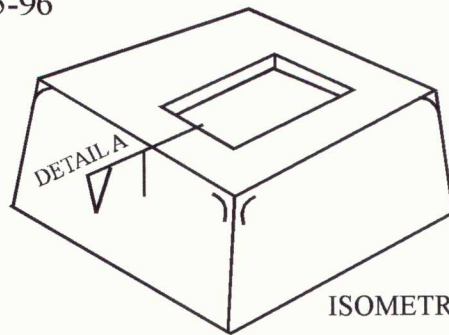

ISOMETRIC

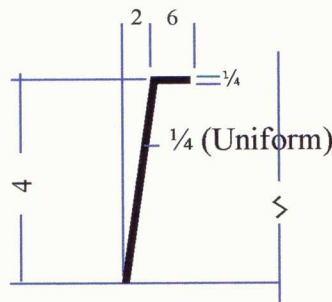

DETAIL A

Note: All dimensions are in inches

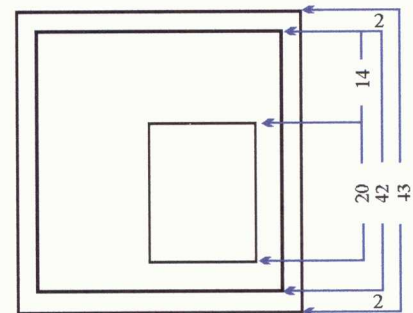

TOP VIEW

G.P. Fiberglass Ltd.  
 Box 3400, Melfort, Saskatchewan  
 CANADA S0E 1A0  
 Phone: (306) 752-3813  
 Fax: (306) 752-5422

All measurements and weights are approximate  
 JANUARY 2002

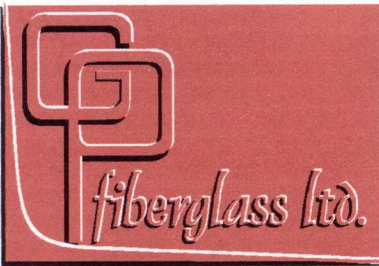

# SIDE PLATE FOR BOX PAD

## FEATURES:

- ◆ Stackable
- ◆ Lightweight
- ◆ Easy to install
- ◆ Never needs painting
- ◆ Adaptable
- ◆ Well designed
- ◆ Economical

## BENEFITS:

- ◆ Freight Savings
- ◆ Minimize storage space

## SHIPPING:

- ◆ part is 15 lbs.
- ◆ part is 2.6 cubic feet
- ◆ 40 per pallet: 50 cubic feet
- ◆ 40 per pallet: 600 lbs.
- ◆ 40 per pallet: 43.5" x 41.75" x 48" high

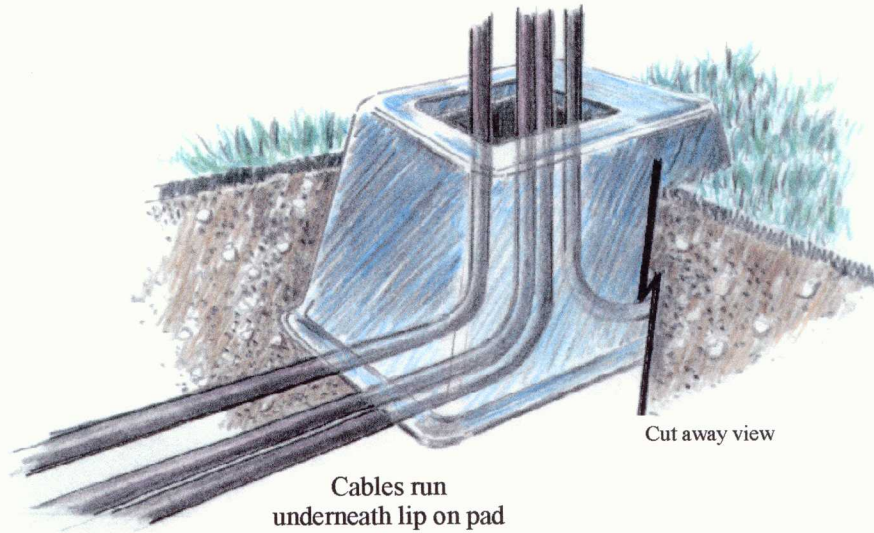

Cut away view

Cables run underneath lip on pad to prevent cutting and damage to cable during frost heave or ground settling

## Fiberglass Side Plate for Box Pad 5-06-04

Code (part #): 515-0618

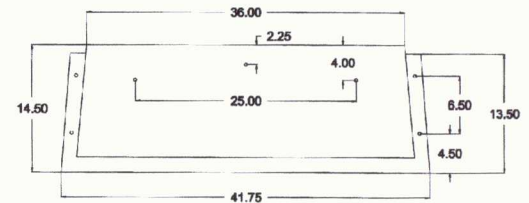

**FRONT VIEW**

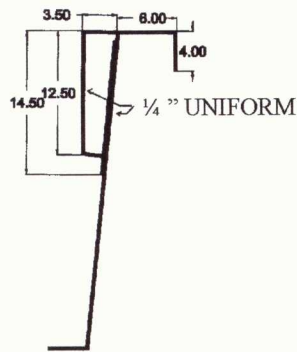

DETAIL 'A'

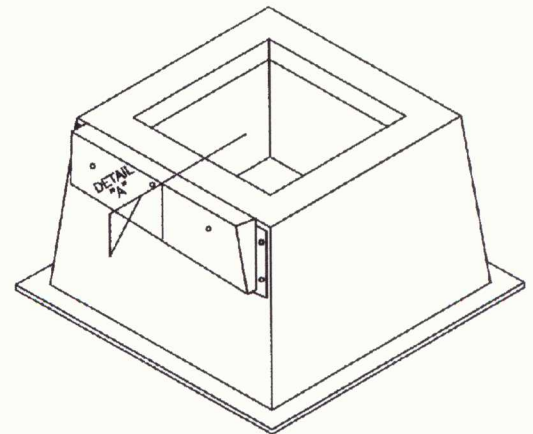

**ISOMETRIC VIEW**

G.P. Fiberglass Ltd.  
 Box 3400, Melfort, Saskatchewan  
 CANADA S0E 1A0  
 Phone: (306) 752-3813  
 Fax: (306) 752-5422

All measurements and weights are approximate  
 JANUARY 2002



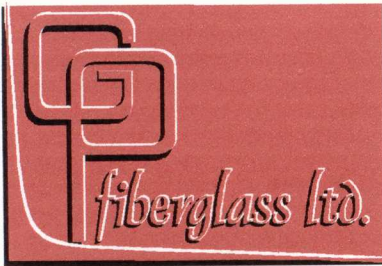

# EXTENSION PAD 12" HIGH

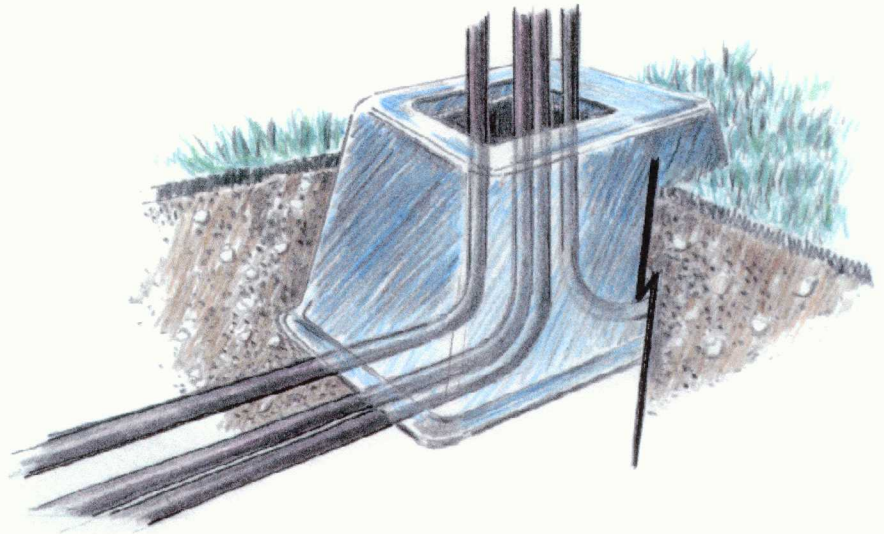

## FEATURES:

- ◆ Stackable
- ◆ Lightweight
- ◆ Easy to install
- ◆ Never needs painting
- ◆ Adaptable
- ◆ Well designed
- ◆ Economical

## BENEFITS:

- ◆ Freight Savings
- ◆ Variety of sizes
- ◆ Variety of shapes
- ◆ Minimize storage space

## SHIPPING:

- ◆ part is 90 lbs.
- ◆ part is 12.25 cubic feet
- ◆ 5 per pallet : 61.25 cubic feet
- ◆ 5 per pallet : 498lbs.
- ◆ 5 per pallet : 42" sq. x 5' High

## FIBERGLASS EXTENSION FOR BOX PAD 5-06-04

Code (part #): 5-06-05

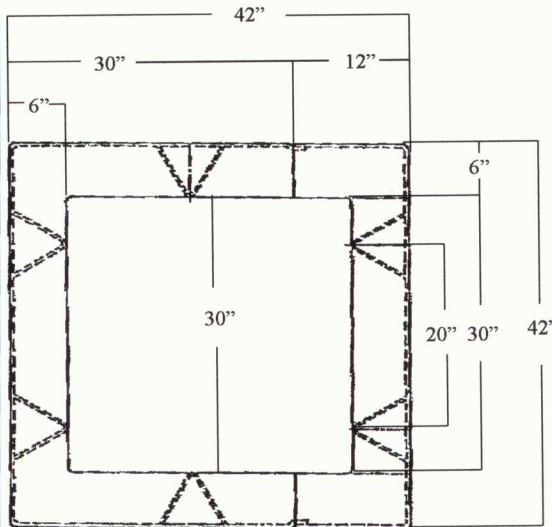

TOP VIEW

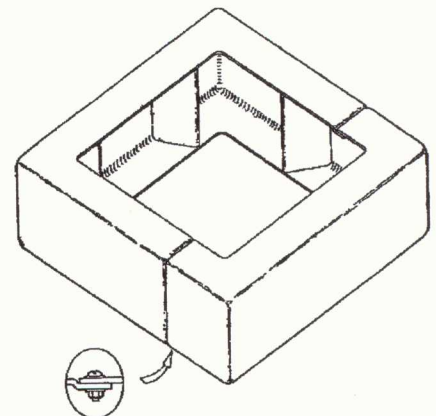

LIP JOINT  
DETAIL



FRONT VIEW

NOTE: ALL DIMENSIONS ARE IN INCHES

G.P. Fiberglass Ltd.  
 Box 3400, Melfort, Saskatchewan  
 CANADA S0E 1A0  
 Phone: (306) 752-3813  
 Fax: (306) 752-5422

All measurements and weights are approximate  
 JANUARY 2002

# RISERWAY SINGLE

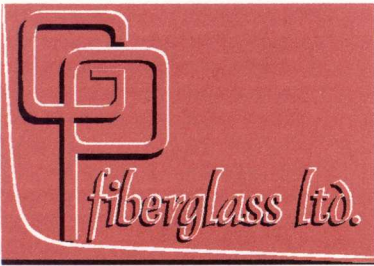

## FEATURES:

- ◆ Stackable
- ◆ Lightweight
- ◆ Easy to install
- ◆ Never needs painting
- ◆ Adaptable
- ◆ Well designed
- ◆ Economical

## BENEFITS:

- ◆ Freight Savings
- ◆ Variety of sizes
- ◆ Variety of shapes
- ◆ Minimize storage space

## SHIPPING:

- ◆ part is 21 lbs.
- ◆ part is 2.75 cubic feet
- ◆ 50 per pallet : 80 cubic feet
- ◆ 50 per pallet : 1150lbs.
- ◆ 50 per pallet : 4' W x 2' x 10' Long

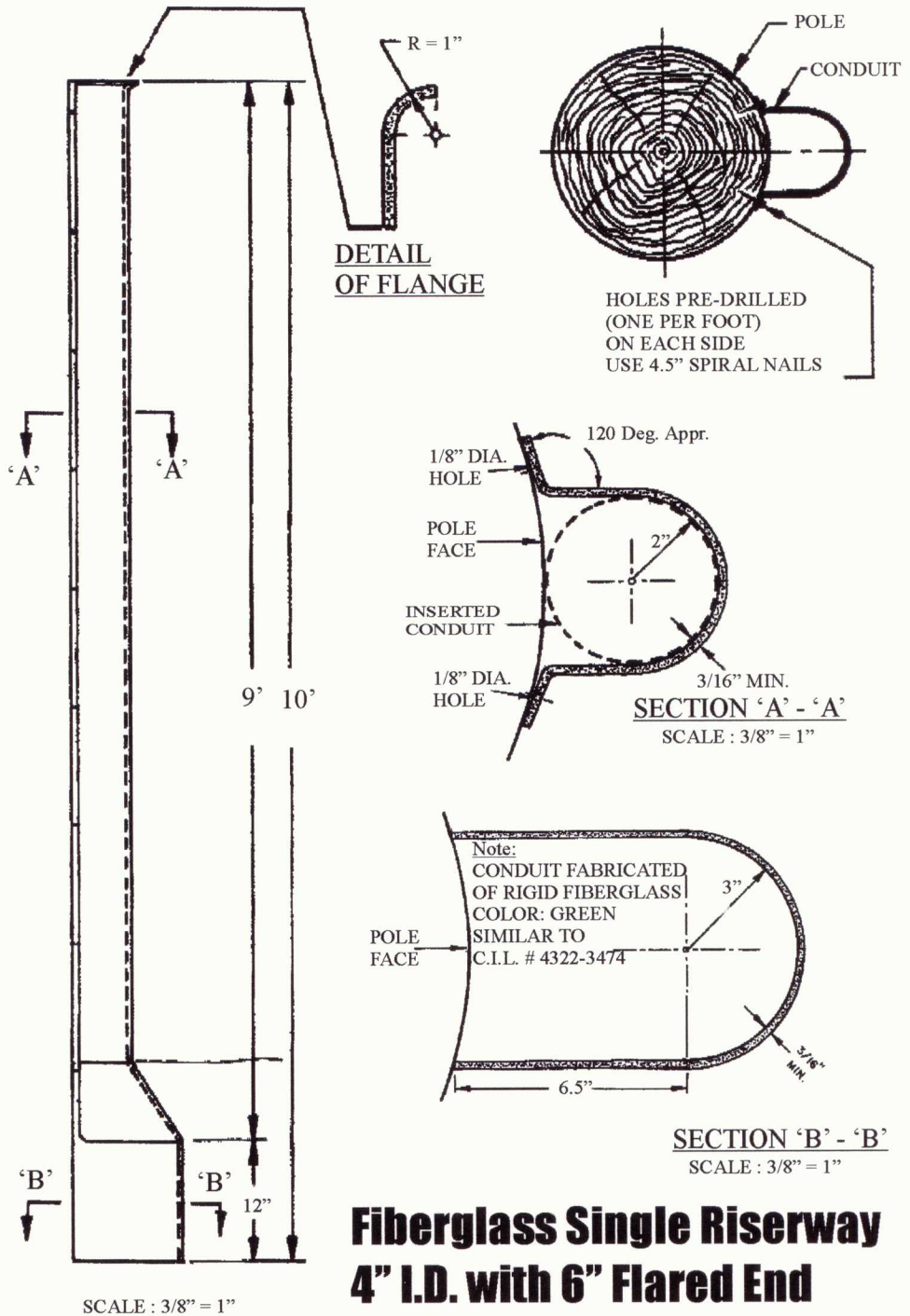

## Fiberglass Single Riserway 4" I.D. with 6" Flared End

Code (part #): 515-0401

NOTE: ALL DIMENSIONS ARE IN INCHES

G.P. Fiberglass Ltd.  
Box 3400, Melfort, Saskatchewan  
CANADA S0E 1A0  
Phone: (306) 752-3813  
Fax: (306) 752-5422

All measurements and weights are approximate  
JANUARY 2002



# ACWM 30 INCH DIAMETER

## FEATURES:

- ◆ COLORED ORANGE  
OR
- ◆ COLORED WHITE
- ◆ Lightweight
- ◆ Easy to install
- ◆ Never needs painting
- ◆ Adaptable
- ◆ Well designed
- ◆ Economical

## BENEFITS:

- ◆ Freight Savings
- ◆ Variety of sizes
- ◆ Variety of shapes
- ◆ Minimize storage space

## SHIPPING:

- ◆ part is shipped in individual cardboard boxes
- ◆ part is 30 lbs.
- ◆ part is 30" x 30" x 18" high
- ◆ part is : 9.25 cubic feet
- ◆ 8 per pallet : 74 cubic feet
- ◆ 8 per pallet : 240lbs.
- ◆ 20 per pallet : 48" sq. x 6' High

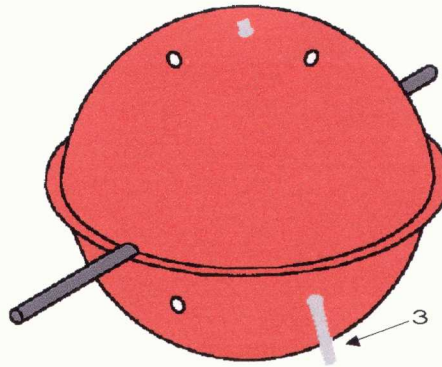

MARKER SPHERE INSTALLED

## FIBERGLASS ACWM FOR LICENSED AIRSTRIP

Code (part #): 05-380-030 ORANGE

Code (part #): 05-380-031 WHITE

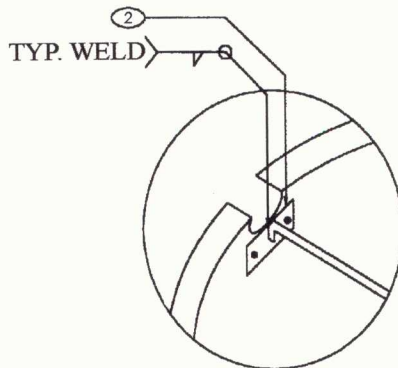

DETAIL 1

SEE  
DETAIL 1

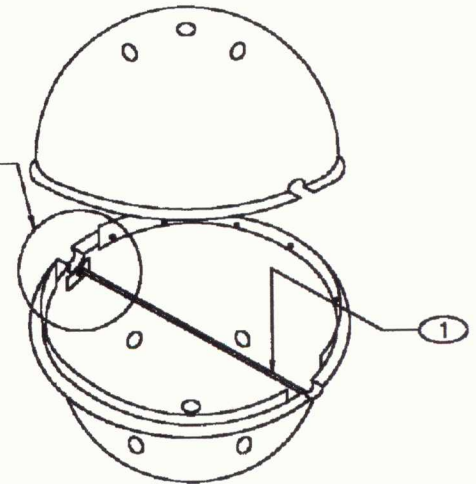

ISOMETRIC VIEW

## MATERIAL LIST

- # 1 - 3/8" COLD ROLLED ROD GRADE 36A
- # 2 - 1 1/2" x 4" - 14 GAUGE PLATES WELDED TO EACH END OF ROD
- # 3 - 3/8" PLATED THREADED ROD C/W 1 LOCK NUT AND 2 NUTS & 2 WASHERS

## NOTES

30" DIAMETER FIBERGLASS SPHERICAL BALL  
( FOR UNLICENSED AIRSTRIP)

SPHERES COLORED WITH INTERNATIONAL ORANGE  
OR WHITE ULTRA VIOLET LIGHT STABILIZED  
GELCOAT

THE ROD TO HOLD THE TWO HALVES TOGETHER IS  
INSTALLED THROUGH THE CENTER TOP AND OFF  
CENTER BOTTOM DRAIN HOLES

G.P. Fiberglass Ltd.  
Box 3400, Melfort, Saskatchewan  
CANADA S0E 1A0  
Phone: (306) 752-3813  
Fax: (306) 752-5422

All measurements and weights are approximate  
JANUARY 2002



# ACWM 20 INCH DIAMETER

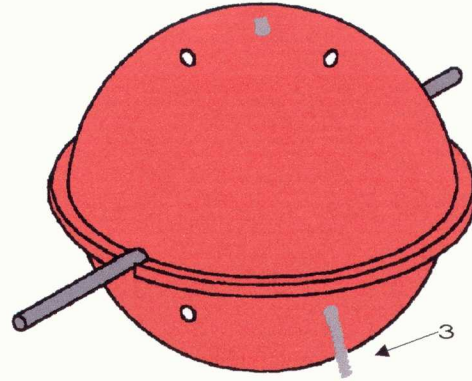

MARKER SPHERE INSTALLED

## FEATURES:

- ◆ Lightweight
- ◆ Easy to install
- ◆ Never needs painting
- ◆ Adaptable
- ◆ Well designed
- ◆ Economical

## BENEFITS:

- ◆ Freight Savings
- ◆ Variety of sizes
- ◆ Variety of shapes
- ◆ Minimize storage space

## SHIPPING:

- ◆ part is shipped in individual cardboard boxes
- ◆ part is 13 lbs.
- ◆ part is 21" x 21" x 12" high
- ◆ part is : 3 cubic feet
- ◆ 20 per pallet : 61.25 cubic feet
- ◆ 20 per pallet : 260lbs.
- ◆ 20 per pallet : 42" sq. x 5' High

## FIBERGLASS ACWM FOR UNLICENSED AIRSTRIP

Code (part #): 05-380-020

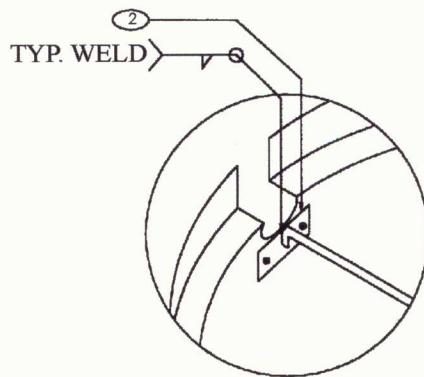

DETAIL 1

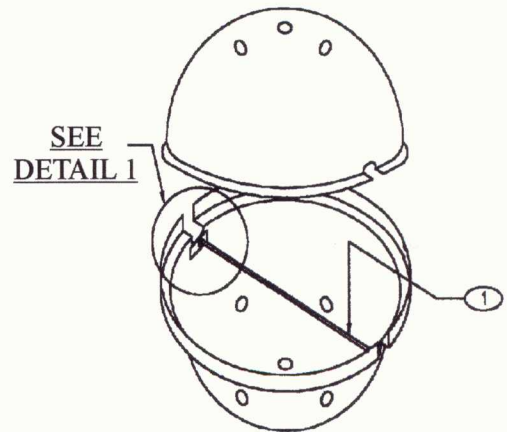

ISOMETRIC VIEW

## MATERIAL LIST

- # 1 - 3/8" COLD ROLLED ROD GRADE 36A
- # 2 - 1 1/2" x 4" - 14 GAUGE PLATES WELDED TO EACH END OF ROD
- # 3 - 3/8" PLATED THREADED ROD C/W 1 LOCK NUT AND 2 NUTS & 2 WASHERS

## NOTES

20" DIAMETER FIBERGLASS SPHERICAL BALL  
( FOR UNLICENSED AIRSTRIP)

SPHERES COLORED WITH INTERNATIONAL ORANGE  
ULTRA VIOLET LIGHT STABILIZED GELCOAT

THE ROD TO HOLD THE TWO HALVES TOGETHER IS  
INSTALLED THROUGH THE CENTER TOP AND OFF  
CENTER BOTTOM DRAIN HOLES

G.P. Fiberglass Ltd.  
Box 3400, Melfort, Saskatchewan  
CANADA S0E 1A0  
Phone: (306) 752-3813  
Fax: (306) 752-5422

All measurements and weights are approximate  
JANUARY 2002

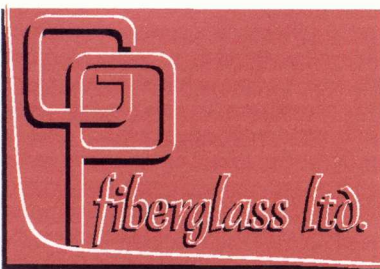

# RISERWAY DOUBLE

HOLES PRE-DRILLED  
(ONE PER FOOT)  
ON EACH SIDE  
USE 4.5" SPIRAL NAILS

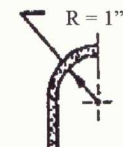

DETAIL OF FLANGE

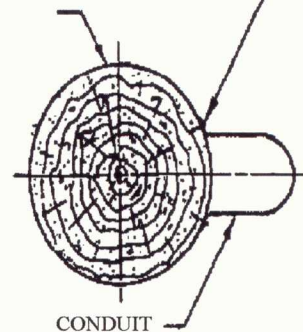

CONDUIT

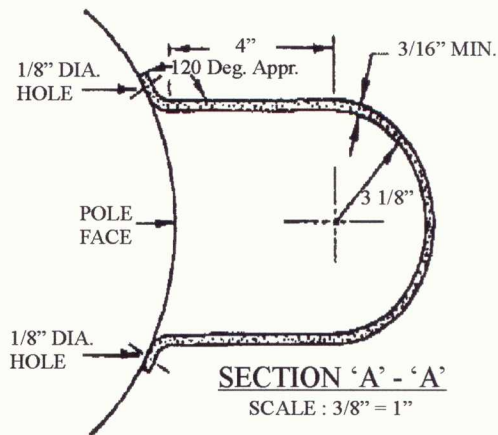
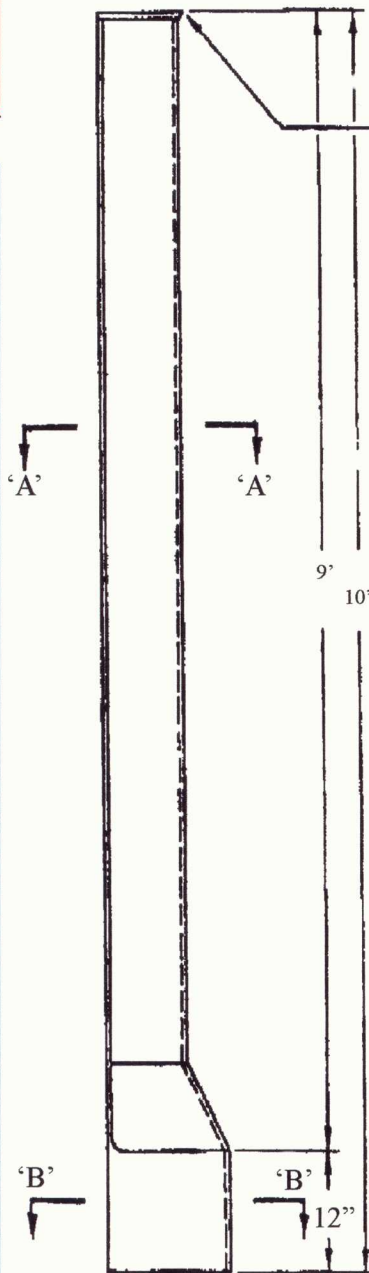

SECTION 'A' - 'A'  
SCALE : 3/8" = 1"

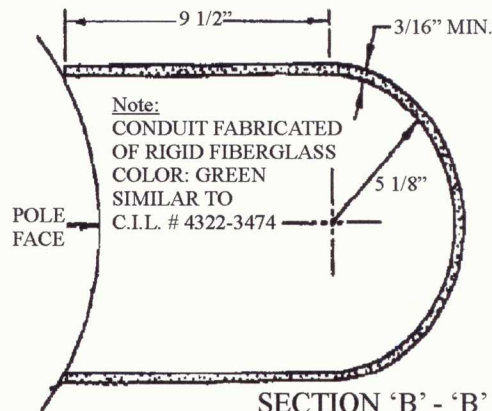

Note:  
CONDUIT FABRICATED  
OF RIGID FIBERGLASS  
COLOR: GREEN  
SIMILAR TO  
C.I.L. # 4322-3474

SECTION 'B' - 'B'  
SCALE : 3/8" = 1"

NOTE: ALL DIMENSIONS ARE IN INCHES

## FEATURES:

- ◆ Stackable
- ◆ Lightweight
- ◆ Easy to install
- ◆ Never needs painting
- ◆ Adaptable
- ◆ Well designed
- ◆ Economical

## BENEFITS:

- ◆ Freight Savings
- ◆ Variety of sizes
- ◆ Variety of shapes
- ◆ Minimize storage space

## SHIPPING:

- ◆ part is 41 lbs.
- ◆ part is 4.8 cubic feet
- ◆ 25 per pallet : 102.5 cubic feet
- ◆ 25 per pallet : 1120lbs.
- ◆ 25 per pallet : 4' W x 2 1/2' x 10' Long

## Fiberglass Double Riserway 6 1/4" I.D. With 10 1/4" Flared End

Code (part #): 515-0403

G.P. Fiberglass Ltd.  
Box 3400, Melfort, Saskatchewan  
CANADA S0E 1A0  
Phone: (306) 752-3813  
Fax: (306) 752-5422

All measurements and weights are approximate  
JANUARY 2002

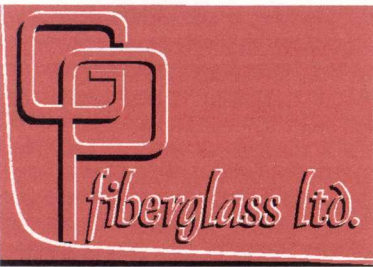

# HANGING ACWM 30 INCH DIAMETER

## FEATURES:

- ◆ COLORED ORANGE OR
- ◆ COLORED WHITE
- ◆ Lightweight
- ◆ Easy to install
- ◆ Never needs painting
- ◆ Adaptable
- ◆ Well designed
- ◆ Economical

## BENEFITS:

- ◆ Freight Savings
- ◆ Variety of sizes
- ◆ Variety of shapes
- ◆ Minimize storage space

## SHIPPING:

- ◆ part is 32 lbs.
- ◆ part is 31"x 31"x 16.5" high
- ◆ part is : 7.5 cubic feet
- ◆ 20 per pallet : 32 cubic feet
- ◆ 20 per pallet : 680lbs.
- ◆ 20 per pallet : 31" Dia. x 6' High

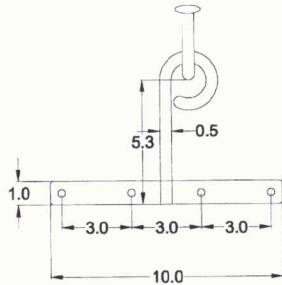

DETAIL 1

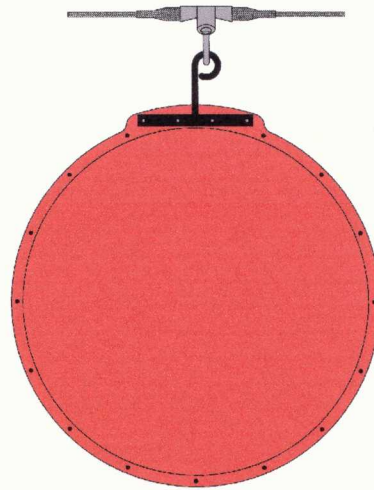

MARKER SPHERE INSTALLED

## FIBERGLASS HANGING ACWM FOR TRANSMISSION LINE

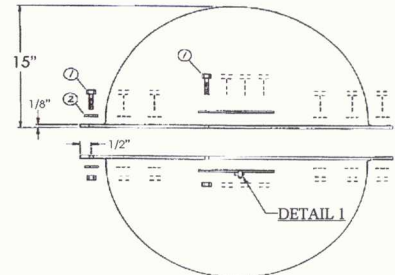

TOP VIEW

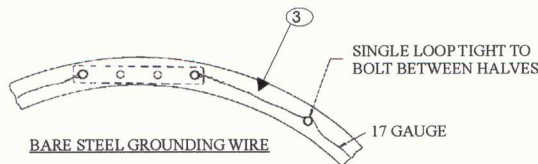

MATERIAL LIST		
NO.	QTY.	DESCRIPTION
1	19	BOLT 1/4" X 1" PLATED c/w SELF LOCKING NUT
2	30	WASHER 5/8" ROUND 5/16" CENTER PLATED
3	9 3/4'	CORONA WIRE CHROME STEEL 17 GAUGE

### NOTES

**30" DIAMETER FIBERGLASS SPHERICAL BALL (FOR TRANSMISSION LINES)**

**SPHERES COLORED WITH INTERNATIONAL ORANGE OR WHITE ULTRA VIOLET LIGHT STABILIZED GELCOAT**

**SUSPENSION BRACKET IS PAINTED WITH ZINC RICH # 31**

G.P. Fiberglass Ltd.  
 Box 3400, Melfort, Saskatchewan  
 CANADA S0E 1A0  
 Phone: (306) 752-3813  
 Fax: (306) 752-5422

All measurements and weights are approximate  
 JANUARY 2002